



SECTION 5

TEST II SAMPLE CONSTRUCTED-RESPONSE ASSIGNMENTS

This section of the Georgia Assessments for the Certification of Educators® (GACE™) Preparation Guide is designed to assist you in responding to the constructed-response assignments on the test. Included in this section are:

- ▶ Constructed-response assignment directions
- ▶ Sample constructed-response assignments
- ▶ Assignment response sheets
- ▶ An example of a strong response to each sample assignment
- ▶ Scoring criteria that will be used in evaluating your response to each assignment

For each sample assignment, you may want to take the following steps to prepare for the test:

- Review the constructed-response assignment directions.
- Print the assignment and the assignment response sheet.
- Use scrap paper to make notes, write an outline, or otherwise prepare your response.
- Use the assignment response sheet to record your response. The assignment response sheet reflects the amount of space available on an actual test.
- After you complete the assignment, review the sample strong response, your response, and the scoring criteria.

CONSTRUCTED-RESPONSE ASSIGNMENT DIRECTIONS

A sample of the directions for the constructed-response assignments is shown in the box below.

CONSTRUCTED-RESPONSE ASSIGNMENT DIRECTIONS

For each constructed-response assignment in this section, you are to prepare a response of up to one page and record it in the area provided on the appropriate Assignment Response Sheet in your answer document.

Read each assignment carefully before you begin. You may use any blank space provided in this test booklet following each assignment to make notes, make preliminary sketches, write an outline, or otherwise prepare your response. *However, each of your final responses must be recorded on the appropriate Assignment Response Sheet in your answer document.*

Your responses will be evaluated based on the following criteria:

- **Purpose:** The extent to which the response fulfills the purpose of the assignment in relation to relevant GACE framework objectives
- **Application of Content Knowledge and Skills:** The extent to which the response accurately and effectively applies content knowledge and skills in relation to relevant GACE framework objectives
- **Supporting Evidence:** The extent to which the response includes appropriate, specific supporting evidence of content knowledge and skills in relation to relevant GACE framework objectives

Evaluation of each response will be based on the criteria above. Your response must be communicated clearly enough to permit a valid judgment of your knowledge and skills. Your responses should be prepared for an audience of educators in the field.

Your responses should be your original work, written in your own words, and not copied or paraphrased from some other work. Please write legibly. You may not use any reference materials during the test. Remember to review your work and make any changes you think will improve your responses.

The selected-response section of the answer document containing your name will be removed from your constructed responses to maintain your anonymity during the scoring process. Do not write your name on any other portion of the answer document, and do not separate any of the sheets from the document.

Please turn the page and begin the constructed-response assignment section of the test.

CONSTRUCTED-RESPONSE ASSIGNMENT ONE

■ Sample Constructed-Response Assignment One

Use the information below to complete the assignment that follows.

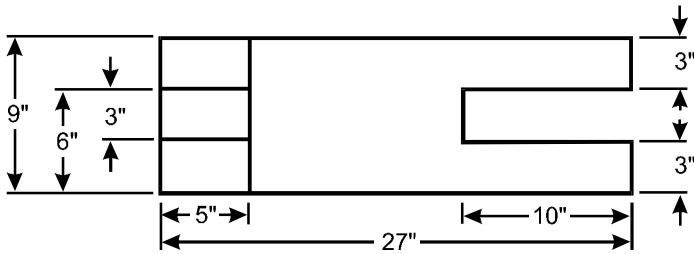

Top

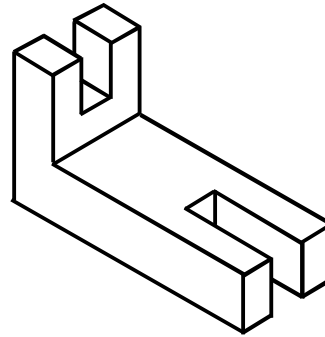

Isometric

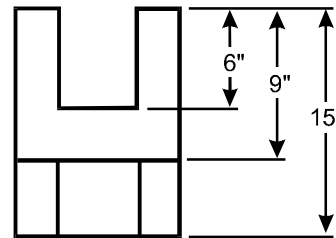

Missing View

Right

The diagram above represents a right side view, a top view, an isometric view, and a missing front view of a three-dimensional object drawn in a third-angle projection.

- Sketch the missing front view of the object; and
- correctly label and dimension your drawing using a scale in which 1 grid unit represents 1 inch.

Section 5: Test II Sample Constructed-Response Assignments

■ Assignment Response Sheet for Sample Constructed-Response Assignment One

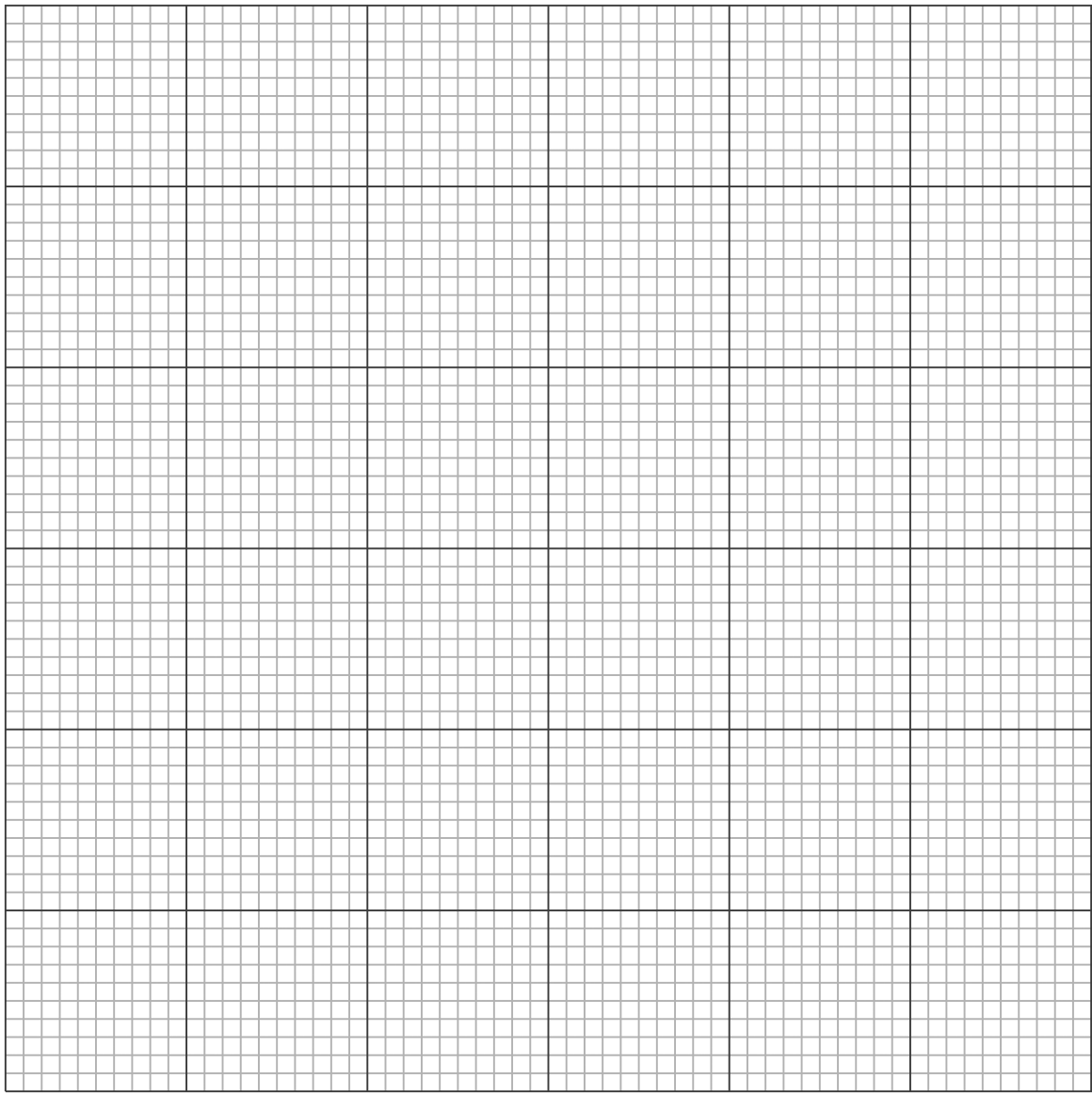

END OF ASSIGNMENT

■ Strong Response to Sample Constructed-Response Assignment One

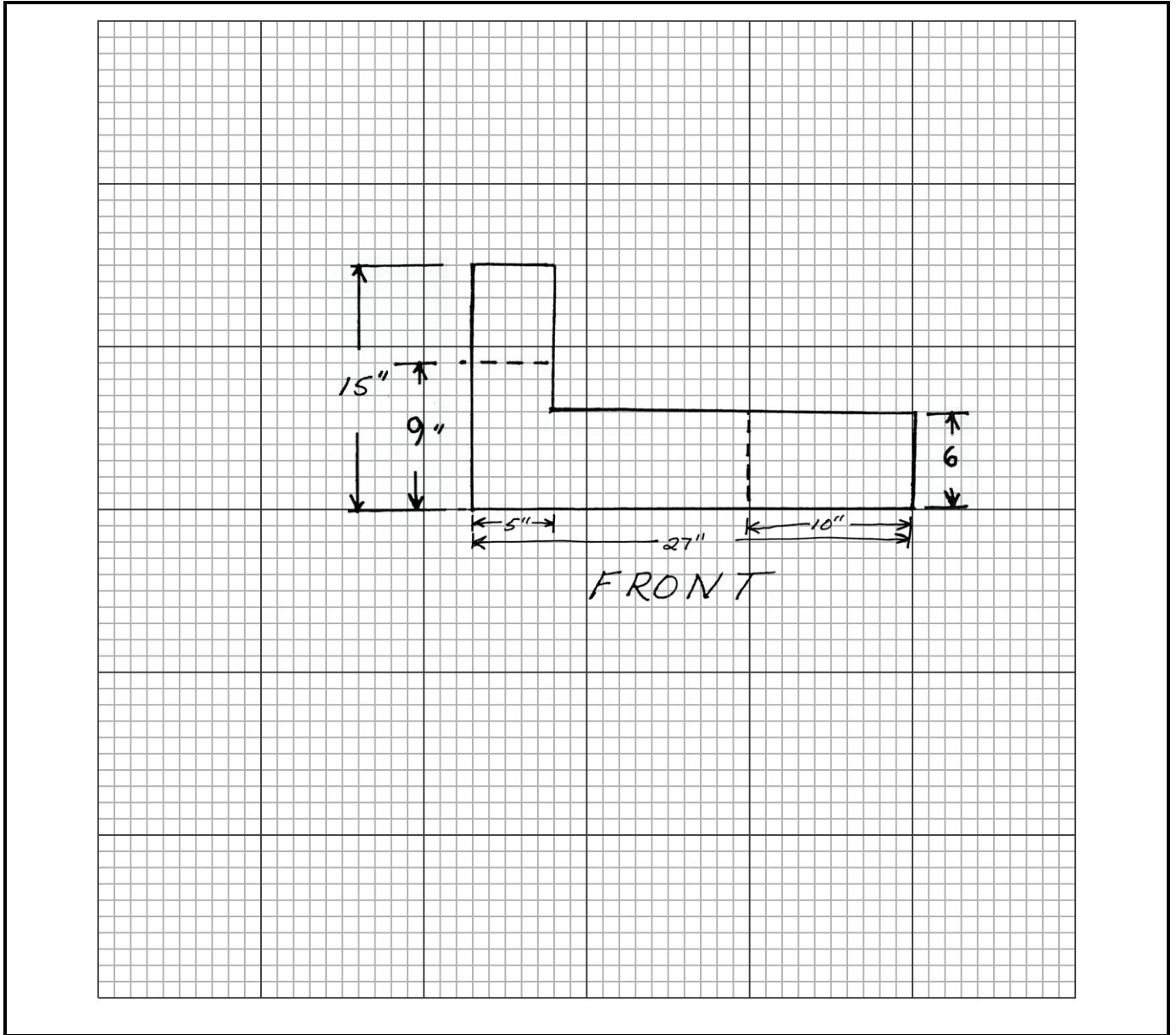

CONSTRUCTED-RESPONSE ASSIGNMENT TWO

■ Sample Constructed-Response Assignment Two

Use the information below to complete the assignment that follows.

A circuit consists of a 9V battery and four resistors. Resistors 1, 2, and 3 are connected in series to create a complete circuit that includes the battery. Resistor 4 is connected in parallel to resistor 2. Resistors 1, 2, 3, and 4 have the values 1Ω , 2Ω , 3Ω , and 4Ω respectively.

- Draw a diagram of the circuit using standard electrical circuit symbols and conventions; and
- calculate the total resistance of the circuit and the current through resistor 4. Show your work.

■ Assignment Response Sheet for Sample Constructed-Response Assignment Two

A large rectangular box with a black border, intended for writing a response. The box is mostly empty, with seven horizontal lines near the bottom edge.

END OF ASSIGNMENT

Section 5: Test II Sample Constructed-Response Assignments

■ Strong Response to Sample Constructed-Response Assignment Two

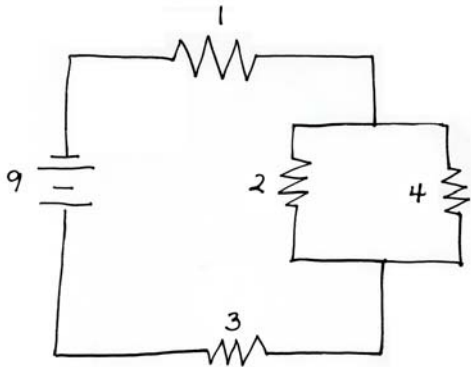

$$R_{2,4} = \frac{R_2 R_4}{R_2 + R_4} = \frac{8}{6} = 1.33 \Omega$$

$$\text{Total resistance} = 1 \Omega + 1.33 \Omega + 3 \Omega + 5.33 \Omega$$

$$\text{Current through circuit} = \frac{9V}{5.33\Omega} = 1.69A$$

$$\text{Current through } R_4 = (1.69A) \left(\frac{2}{6} \right) = 0.56A$$

CRITERIA FOR SCORING YOUR RESPONSE

Each response will be evaluated based on the following criteria.

PURPOSE	The extent to which the response fulfills the purpose of the assignment in relation to relevant GACE framework objectives
APPLICATION OF CONTENT KNOWLEDGE AND SKILLS	The extent to which the response accurately and effectively applies content knowledge and skills in relation to relevant GACE framework objectives
SUPPORTING EVIDENCE	The extent to which the response includes appropriate, specific supporting evidence of content knowledge and skills in relation to relevant GACE framework objectives

Each response is rated on a three-point scale. The three score points of the score scale correspond to varying degrees of performance that are related to the above criteria.

Score	Description
3	<p>The "3" response reflects thorough understanding of relevant content knowledge and skills as defined in relevant GACE framework objectives.</p> <ul style="list-style-type: none"> • The response fully achieves the purpose of the assignment. • The response demonstrates an accurate and effective application of relevant content knowledge and skills. • The response provides appropriate, specific supporting evidence of relevant content knowledge and skills.
2	<p>The "2" response reflects general understanding of relevant content knowledge and skills as defined in relevant GACE framework objectives.</p> <ul style="list-style-type: none"> • The response largely achieves the purpose of the assignment. • The response demonstrates a generally accurate, generally effective application of relevant content knowledge and skills. • The response provides some appropriate and general supporting evidence of relevant content knowledge and skills.
1	<p>The "1" response reflects limited or no understanding of relevant content knowledge and skills as defined in relevant GACE framework objectives.</p> <ul style="list-style-type: none"> • The response partially achieves or fails to achieve the purpose of the assignment. • The response demonstrates limited, inaccurate, and/or ineffective application of relevant content knowledge and skills. • The response provides limited or no appropriate, specific supporting evidence of relevant content knowledge and skills.

Please note: A response that is unrelated to the assigned topic, illegible, not primarily in the target language, or lacking a sufficient amount of original work to score will be considered **unscorable**. If there is no response to the assignment, then the response will be considered **blank**.